

Short description force transducer FFB01-P

The TEQFORT GmbH develop, produce and marketed on strain gauge based sensors for force and torque measuring as well as the required electronic. The name TEQFORT represent for - Test Equipment Force Torque - and for quality at high and highest precision.

The force transducer of the model range FFB01-P is determined by a design that is well known in the metrology field as a bending ring sensor. With its precision, it is particularly well suited for all tensile and pressure applications in the field of high requirements of the proofing and test technology. Especially for measuring tasks, where a high-precision measurement at high bandwidth is required, it is characterized.



- Nominal load 1 kN – 500 kN
- For static and dynamic application
- Accuracy 0,03 – 0,04 %
- Fatigue resistant up to ± 100 % at 1 mV/V (0,8 mV/V) version
- Sensors hermetically sealed and filled with inert gas
- Insensitive to parasitic forces and moments

Short description force transducer FFB01-P

The model FFB01-P can be mounted directly over the outer flange and the preferred center flange by means of various adapters, from 1 kN, individually. The widely available load sizes of the program as well as versions in 1 mV/V (0,8 mV/V), for dynamic applications up to 100%, make this force sensor so versatile. The combination of size and accuracy characterize our model FFB01-P in such a way that it can be found again in the most diverse applications of the automotive, railway, aerospace and even wind power sector.



Options

- Second measuring circuit for redundancy
- Bending circuits for M_x and M_y
- Attachments for mounting and initiation of tensile and compressive forces

Technical Data

Nominal load	$\pm F_{nom}$	kN	1,0 / 2,5	4,0 / 5,0 / 6,3	10 / 20	25	40 / 50 / 63	100 / 150 / 160	200 / 250	400 / 500
Accuracy		%								$\pm 0,04$
Linearity error	d_{lin}	%								$\pm 0,04$
Hysteresis	h	%								$\pm 0,05$
Reversibility error	v	%								$\pm 0,2$
Measuring range		%					1 - 100			
Reproducibility		%					$\pm 0,003$			
Creep		%					$\pm 0,03$			
Eccentricity effect		%/mm					0,015			
Torque effect		%/mm F_{nom}					0,005			
Bending moment effect		%/Nm					$< 0,003$			
Lateral force effect		%/0,1· F_{nom}					0,02			
Characteristic value difference, tension/compression force	d_{zD}	%					0,07			0,1
Temperature effect on characteristic value per 10 K	TK_c	%/10K					0,015			
Temperature effect on zero signal per 10 K	TK_0	%/10K					0,015			
Nominal temperature range	$B_{T,nom}$	°C					+ 10 up to +60			
Operating temperature range	$B_{T,G}$	°C					- 40 up to + 120			
Rated characteristic value (1*)	C_{nom}	mV/V	1 (0,8)				2 (1)			
Zero signal deviation	$d_{s,0}$	%					0,5			
Characteristic value tolerance	d_c	%					0,2			
Input resistance	R_e	Ω					ca. 1000			
Isolation resistance	R_{is}	Ω					$> 10^9$			
Range of supply voltage	$B_{U,G}$	V					5 up to 15			
Protection class (EN 60529)		IP					67			

(1*) In the model range FFB01-P, all sensors can be carrying out in 0,8 mV/V or 1 mV/V version for dynamic applications. PRN, depending on the load size, the height of the sensor may change.

Technical Data

Nominal load	$\pm F_{nom}$	kN	4 / 5 / 6,3	10 / 20 / 25	40 / 50 / 63	100	150	160	200 / 250	400 / 500
Permissible vibration stress (2*)		%	$\pm 80 / (\pm 100)$							
Basic resonance frequency (3*)	f_G	kHz	3/3,5/4	4	6,8	5			3,7	4
Proportionally moved mass	m_{mess}	kg	0,12	0,22	0,35	0,8			2,4	4
Mass	m	kg	0,5	1	1,2	3,7			10,4	20
Nominal deflection (3*)		mm	0,093/0,08/0,086	0,071		0,12	0,15	0,16	0,19	0,21
Static limit force		%	150							
Static transverse force limit		%	100							
Static breaking load		%	300							
Permitted static eccentricity		mm	10			15			20	25
Static bending moment limit		kNm	0,25	0,4	1	3,5	5		10	20

(2*) With a nominal characteristic value of 0,8 mV/V or 1 mV / V, a vibration stress of up to $\pm 100\%$ is applicable.

(3*) All information of the sensor FFB01-P for 2 mV / V (1mV/V) version; Data for 1 mV / V (0,8 mV/V) available on request.

All sensors of the model series FFB01-P from 1 kN are also available in a version with central thread.

Measuring line connection

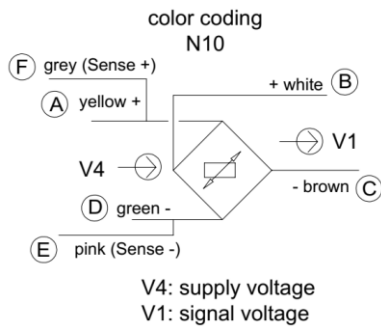

		Plug-in cable connection ¹⁾	Fixed connection, cable ends open
		connection socket	plug
			grey cable sheath Ø 6,6 mm in pairs twisted, 3x2x0,25mm ² temperature range -40°C bis + 80°C
Connection		Contact	Colour of conductor
Supply voltage (+)	U_{in+}	A	yellow
Supply voltage (-)	U_{in-}	D	green
Measuring signal (+)	U_{out+}	B	white
Measuring signal (-)	U_{out-}	C	brown
Sense signal (+)	Sense +	F	grey
Sense signal (-)	Sense -	E	pink
Screen			black

1) Connection view each solder side

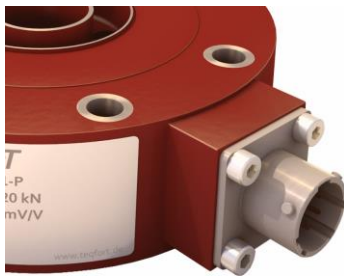

Options for connection and measuring line

Bayonet connection for rough weather and offshore area

Fixed line connection

Tangential arrangement of the connection on request

Standard measuring line length 5 meters, other lengths individually

Extended temperature range of the sensor with measuring line available for temperatures up to 200 °C

Amplifier in the measuring line or in the connection housing, see **EAW01**

Version with redundant measuring circuit



For design with a second (redundant) measuring circuit, the same technical data apply as for the first measuring circuit.

Version with bending moment circuits

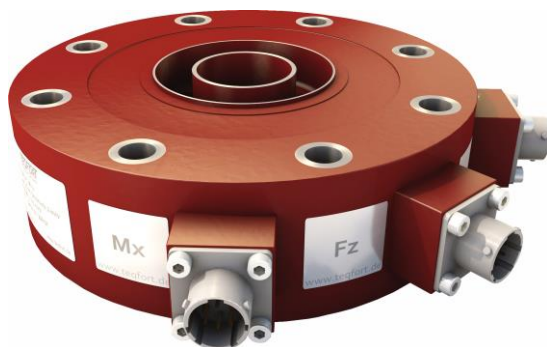

Nominal load	$\pm F_{nom}$	kN	1 – 500 kN (2mV/V)	1 – 500 kN (1mV/V)
Nominal bending moment	Mb_{nom}	Nm	$F_{nom} \cdot 8 \text{ mm}$	$F_{nom} \cdot 12 \text{ mm}$
Reproducibility		%	0,01	
Temperature effect on zero signal	TK_0	%/10K	0,2	
Temperature effect on characteristic value	TK_C	%/10K	0,2	
Rated characteristic value	C_{nom}	mV/V	ca. 0,5	
Input resistance	R_e	Ω	1000	
Range of supply voltage	$B_{U,G}$	V	5 - 15	

Sensor dimensions 1 kN – 6,3 kN

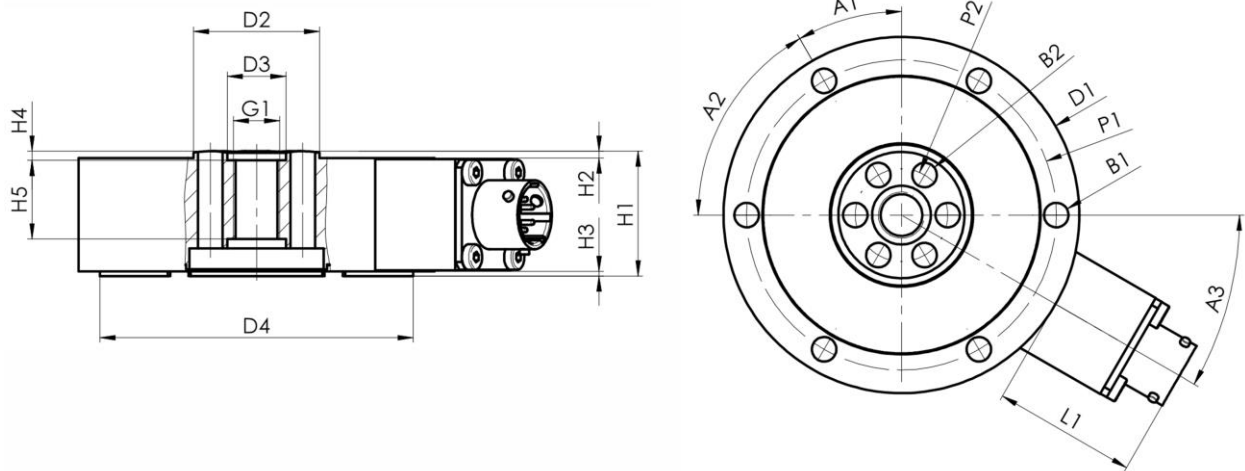

Nominal load	$\pm F_{nom}$	kN	1 / 2,5 / 4 / 5 / 6,3
Height	H1	mm	27
Height	H2	mm	1,5
Height	H3	mm	1
Height	H4	mm	2
Height	H5	mm	17
Diameter	D1	mm	77
Diameter	D2	mm	27,3
Diameter	D3	mm	12,7 _{+0,05}
Diameter	D4	mm	68 _{-0,05}
Pitch circle diameter	P1	mm	67 _{±0,1}
Pitch circle diameter	P2	mm	20 _{±0,1}
Bore	B1	mm	5,3
Bore	B2	mm	5,3
Thread	G1		M10 x 1
Angle	A1		30°
Angle	A2		6 x 60
Angle	A3		30°
Length connection	L	mm	31

Sensor dimensions 10 kN – 160 kN

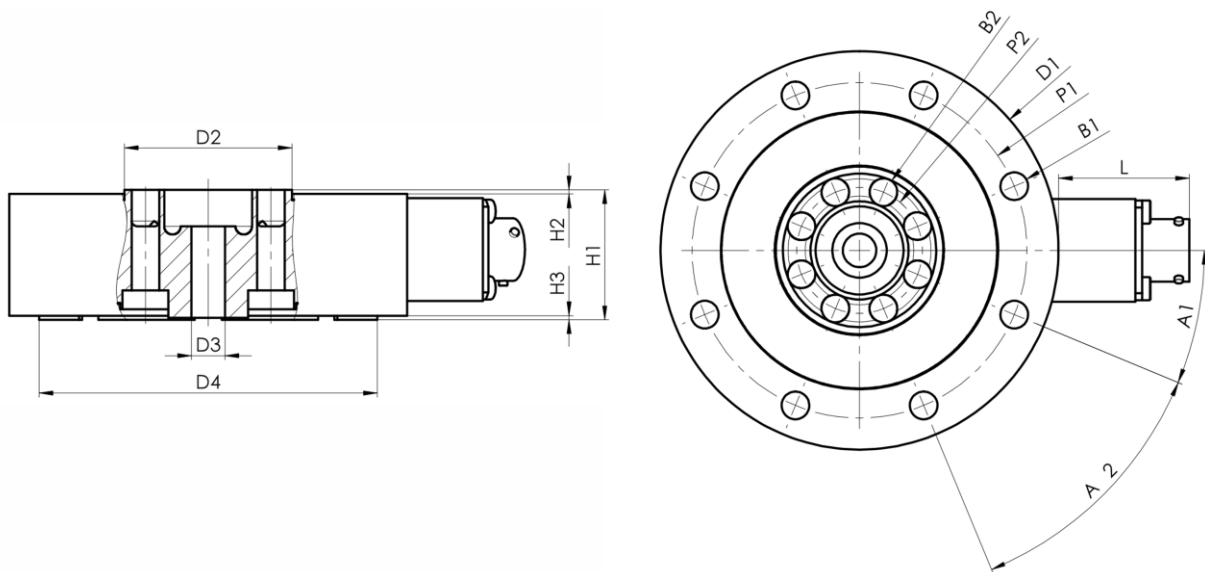

Nominal load	$\pm F_{nom}$	kN	10 / 20	25	40 / 50 / 63	100 / 150 / 160
Height	H1	mm	31			49
Height	H2	mm	1	1,5	0,5	
Height	H3	mm	1			
Diameter	D1	mm	95	101	148	
Diameter	D2	mm	40	38,6	63	
Diameter	D3	mm	8 _{H9}			10 _{+0,1}
Diameter	D4	mm	81 _{-0,1}	87 _{-0,1}	131,4 _{-0,1}	
Pitch circle diameter	P1	mm	80 _{±0,1}	86 _{±0,1}	130 _{±0,1}	
Pitch circle diameter	P2	mm	30 _{±0,1}			45 _{±0,1}
Bore	B1	mm	6,6			11
Bore	B2	mm	6,6			11
Angle	A1		22,5			
Angle	A2		8 x 45°			
Length connection	L	mm	32			

Sensor dimensions 200 kN – 500 kN

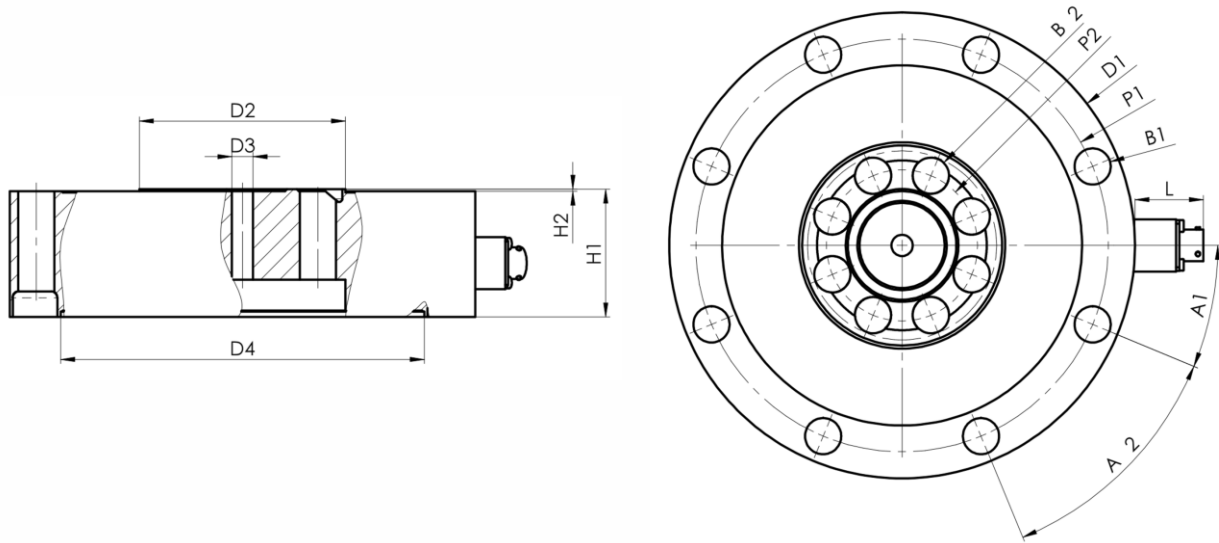

Nominal load	$\pm F_{nom}$	kN	200 / 250	400 / 500
Height	H1	mm	60	80
Height	H2	mm	1	
Diameter	D1	mm	219	270
Diameter	D2	mm	97	128
Diameter	D3	mm	10,05 \pm 0,1	10 \pm 0,1
Diameter	D4	mm	171,05 \pm 0,1	203 \pm 0,1
Pitch circle diameter	P1	mm	194 \pm 0,1	235 \pm 0,1
Pitch circle diameter	P2	mm	71 \pm 0,1	95 \pm 0,1
Bore	B1	mm	17	22
Bore	B2	mm	17	22
Angle	A1		22,5	
Angle	A2		8 x 45°	
Length connection	L	mm	33	